



USER MANUAL

STRAIGHT GRINDERS

MODELS : FG-6H-1, -1M



FG-6H-1

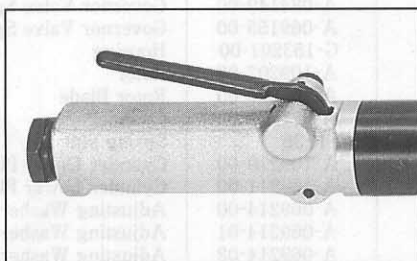

FG-6H-1M

SPECIFICATIONS

Model	Grinding Wheel		Free Speed min ⁻¹	Spindle Thread Size in	Overall Length		Mass		Max. Air Consumption		Air Inlet Thread Size		Air Hose Size	
	mm	in			mm	in	kg	lb	m ³ /min	ft ³ /min	in	mm	mm	1/2
FG-6H-1	150×25×15.8	6×1×5/8	6,300	5/8-11	434	17 3/32	3.5	7.7	1.20	42.4	PT or NPT 3/8	12.7	1/2	
FG-6H-1M	150×25×15.8	6×1×5/8	6,300	5/8-11	531	20 7/8	3.5	7.5	1.20	42.4	PT or NPT 3/8	12.7	1/2	

The performance figures are at 0.63MPa (6.3bar).

⚠ Refer to "The Instructions and Warning for Safety Use" enclosed in each tool box.

FUJI AIR TOOLS CO., LTD.

2-1-14 Kamiji, Higashinari-ku, Osaka, 537-0003 Japan

Tel : (06) 6972-2335

Fax : (06) 6972-2250

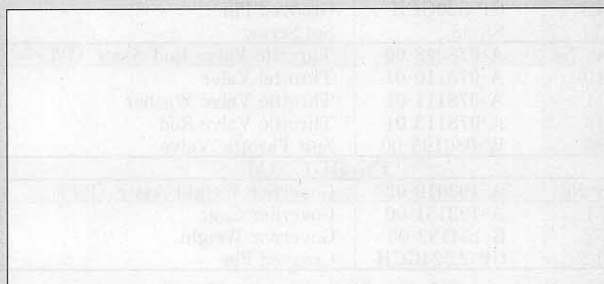

BOLT & NUT SETTERS
SCREW DRIVERS

ABRASIVE TOOLS

DRILLS · TAPPERS

PERCUSSION TOOLS

AIR MOTORS & OTHERS

OTHER PRODUCTS

PARTS LIST MODEL: FG-6H-1, -1M

EXPLODED VIEW

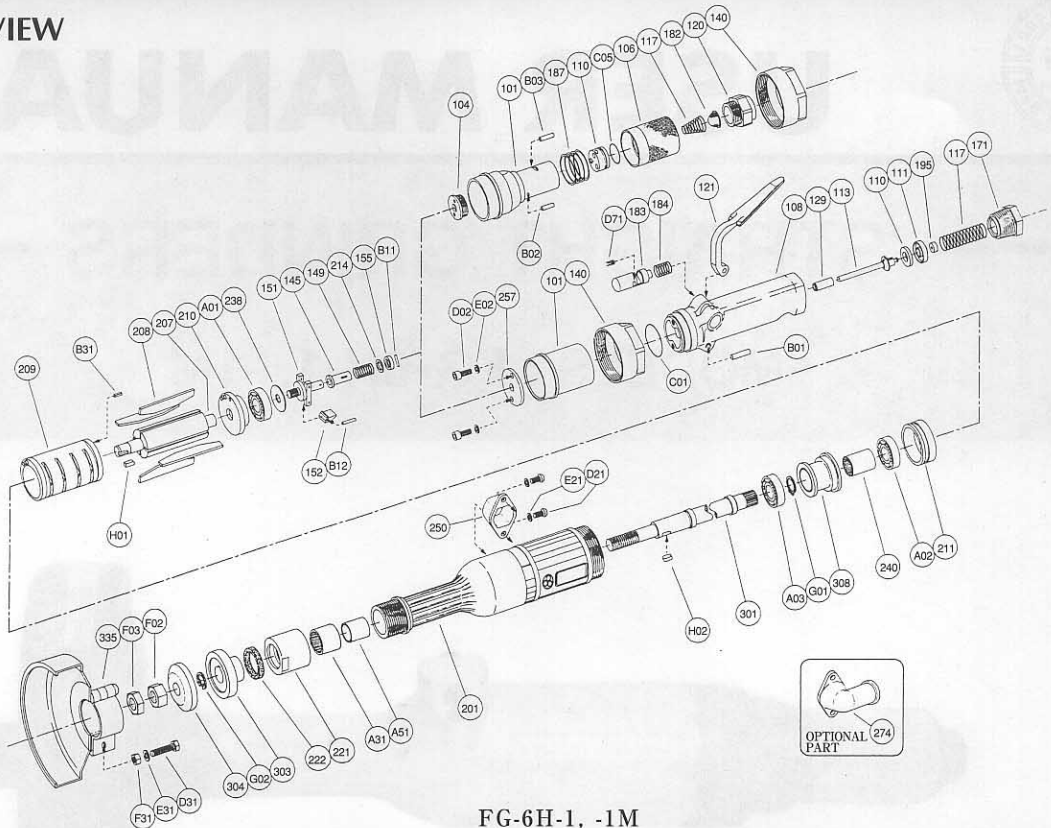

PARTS LIST

FG-6H-1, -1M

Index No.	Parts No.	Parts Name	Qt.
FG-6H-1			
Ass'y No.	G-153001-00	Housing Cover Ass'y <PT>	
Ass'y No.	G-153001-02	Housing Cover Ass'y <NPT>	
101	G-153101-00	Housing Cover	1
104	A-077104-01	Bushing	1
106	A-077106-03	Throttle Valve Handle	1
110	A-077110-00	Throttle Valve	1
117	A-077117-00	Throttle Valve Spring	1
120	A-077120-00	Throttle Valve Cover <PT>	1
	A-077120-01	Throttle Valve Cover <NPT>	1
182	W-057182-00	Strainer	1
187	A-077187-01	Throttle Valve Handle Spring	1
B01	NR-415	Needle Roller	1
B02	NR-413	Needle Roller	1
C01	O-S22	"O" Ring	1
FG-6H-1M			
Ass'y No.	G-153001-01	Housing Cover Ass'y <PT>	
Ass'y No.	G-153001-03	Housing Cover Ass'y <NPT>	
101	G-153101-01	Housing Cover	1
140	G-153140-00	Cup Nut	1
257	A-109257-00	Washer	1
C05	O-S34	"O" Ring	1
D02	CS-518	Cap Screw	2
E02	SW-5	Spring Washer	2
Ass'y No.	A-096003-00	Throttle Valve Body Ass'y <PT>	
Ass'y No.	A-096003-03	Throttle Valve Body Ass'y <NPT>	
108	A-096003-50	Throttle Valve Body	1
(129)	A-078129-00	Throttle Valve Rod Bushing	1
117	A-078117-01	Throttle Valve Spring	1
121	A-078121-00	Throttle Valve Lever	1
171	IB-6N30S0	Inlet Bushing <PT>	1
	IB-6N3NS0	Inlet Bushing <NPT>	1
183	A-078183-01	Lock Key	1
184	A-078184-00	Lock Spring	1
B03	GP-520GCH	Grooved Pin	1
D71	SS-48	Set Screw	1
Ass'y No.	A-078008-00	Throttle Valve Rod Ass'y <PT>	
110	A-078110-01	Throttlet Valve	1
111	A-078111-01	Throttle Valve Washer	1
113	A-078113-01	Throttle Valve Rod	1
195	W-080195-00	Sub Throttle Valve	1
FG-6H-1, -1M			
Ass'y No.	A-193010-02	Governor Weight Ass'y <PT>	
151	A-193151-00	Governor Cage	1
152	G-154152-00	Governor Weight	2
B12	GP-2.524GCH	Grooved Pin	2

Index No.	Parts No.	Parts Name	Qt.
140	G-153140-00	Cup Nut <For FG-6H-1>	1
145	A-077145-00	Governor Valve	1
149	A-077149-03	Governor Valve Spring	1
155	A-069155-00	Governor Valve Spring Holder	1
201	G-153201-00	Housing	1
207	A-109207-00	Rotor	1
208	A-109208-00	Rotor Blade	1
209	A-077209-00	Cylinder	1
(B31)	SP-38	Spring Pin	1
210	A-109210-00	Cylinder Upper Plate	1
211	A-109211-00	Cylinder Lower Plate	1
214	A-069214-00	Adjusting Washer <T=0.2>	1
	A-069214-01	Adjusting Washer <T=0.3>	1
	A-069214-02	Adjusting Washer <T=0.5>	1
221	G-044221-00	Spindle Bearing Cover	1
222	G-044222-00	Felt Ring	1
238	A-109238-00	Bearing Cover 	1
240	G-152240-00	Coupling	1
250	G-152250-00	Exhaust Cover	1
D21	CS-510B	Cap Screw	2
E21	SW-5	Spring Washer	2
301	G-153301-00	Wheel Spindle	1
303	G-153303-01	Wheel Flange <A>	1
304	G-153304-03	Wheel Flange 	1
308	G-152308-00	Spacer	1
335	G-045335-00	Wheel Guard	1
(D31)	HS-625	Hexagon Bolt	1
(E31)	SW-6	Spring Washer	1
(F31)	N-6	Nut	1
A01	BB-6002MN	Ball Bearing	1
A02	BB-6301	Ball Bearing	1
A03	BB-6202	Ball Bearing	1
A31	NB-HK2020	Needle Bearing	1
A51	IR-172020.5	Inner Race	1
B11	NR-2.515.8	Needle Roller	1
F02	N-U5/8	Nut	1
F03	N-U5/8 (3)	Nut	1
G01	SR-S15	Snap Ring	1
G02	SR-S16	Snap Ring	1
H01	K-4410F	Key	1
H02	K-4410	Key	1
OPTIONAL PART			
274	G-152274-00	Exhaust Hose Joint	1

□ Ass'y No. denotes the assembled parts comprising of more than 1 pc. of parts. The related parts are shown in the thick frame.

□ #108, 209, and 335 are supplied together with parts shown in ().

□ Specify parts number and quantity in ordering.

■ Standard Accessories : F-125..... Open-End Wrench 1.